

ACO Drain® | Sumps

4'x4'x4' w/ Gray Iron Frame & Slotted Grate Spec Sheet

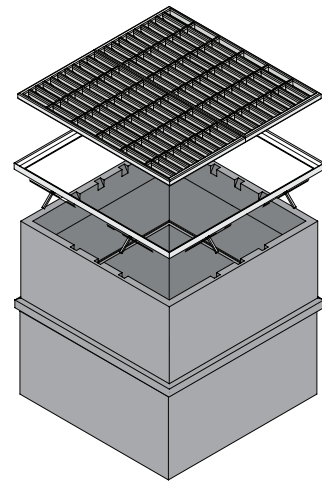

Top

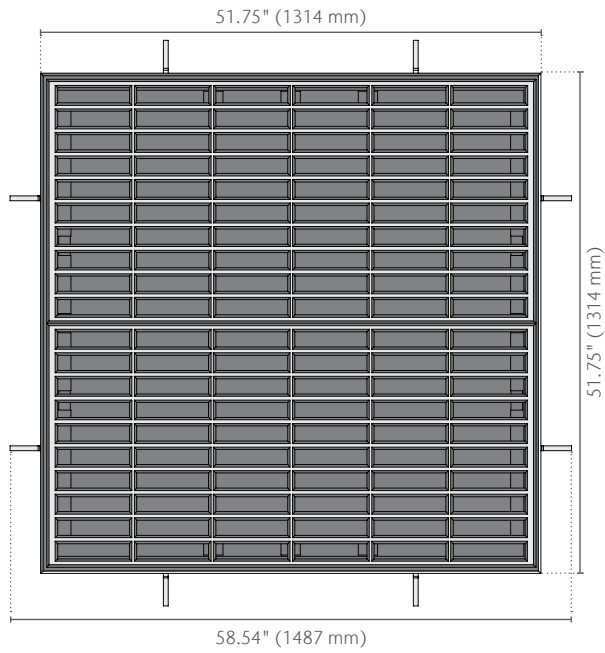

Side

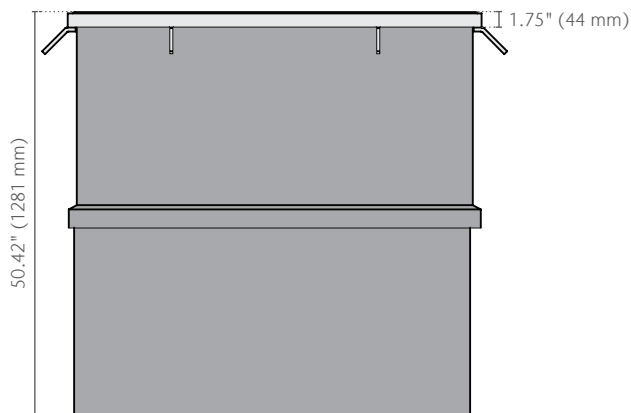

4'x4'x4' w/ Gray Iron Frame & Slotted Grate Spec Sheet



Heavy Duty Application

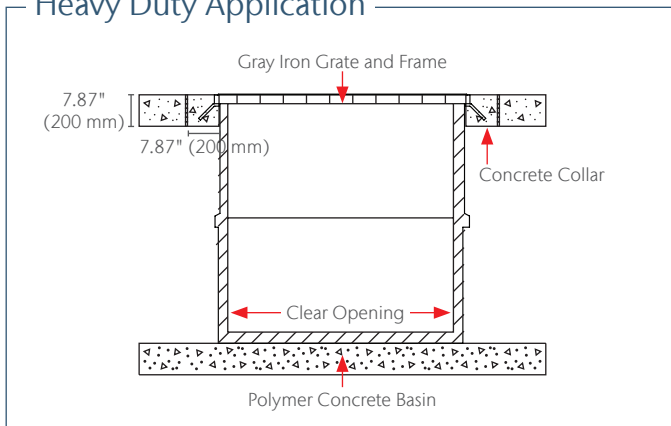

Product Name	Part No.	Invert Depth in (mm)	Volume gal	Weight lbs
4'x4'x4' Sump Box	05714	49.88 (1267)	475.0	995.0
Gray Iron Frame & Slotted Grate	05978	49.25 (1251)	-	1300.0

Specification Summary

General

The sump box shall be ACO Drain as manufactured by ACO, Inc. or similar approved.

Grates

Frame material is gray iron. Grates provide 48% open area (1,360 in²). Grate is slotted gray iron and is supplied as a 2-part unit. After grate removal there shall be uninterrupted access to the sump box to aid maintenance.

Installation

The sump box and grates shall be installed in accordance with the manufacturer's installation instructions and recommendations.

AASHTO M306 requires that castings bear a minimum of 40,000 lbs on a 9" x 9" area. This represents a 2.5 safety factor over the 16,000 lb requirement of H20 and HS20. This load designation is appropriate for general traffic applications. Loading criteria is 40,000–100,000 lbs.

Materials

Products shall be manufactured from polymer concrete and have minimum properties as follows:

- Compressive strength: 13,053 psi
- Flexural strength: 3,191 psi
- Water absorption <0.1% by weight
- Overall width: 58.54" (1,487 mm)
- Overall length: 58.54" (1,487 mm)
- Overall depth: 50.42" (1,281 mm)
- Invert depth: 49.25" (1,251 mm)

Pre-cast units shall be manufactured with drill-outs for channel and pipe connections and have a wall thickness of at least 0.75" (19 mm).

ACO, Inc.

© January 2026 ACO, Inc.

All reasonable care has been taken in compiling the information in this document. All recommendations and suggestions on the use of ACO products are made without guarantee since the conditions of use are beyond the control of the company. It is the customer's responsibility to ensure that each product is fit for its intended purpose and that the actual conditions of use are suitable. ACO, Inc. reserves the right to change products and specifications without notice.

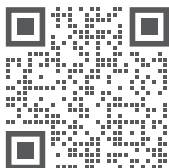

info@acousa.com
www.acousa.com

